



MFIO800 ON B55

Features

- Only 21" (533 mm) wide.
- Produces up to 940 lbs (426 kg) of ice per day.
- *SystemSafe* load monitoring system constantly checks workload on gearbox - shutting down system before a problem develops and preventing costly repairs.
- Water sensor eliminates low or no water failures and cannot be affected by adverse water conditions.
- Rugged stainless steel evaporator and auger ensures reliability.
- Industrial-grade roller bearings and heavy-duty gearbox provide years of trouble-free service.

Options & Accessories

WATER FILTERS			
Ice Machine Model	Manifold		Inline
	System	Replacement	System
MFIO800	IFQ1	IOMQ (1)	IF14C / IF18C
MFIO805	IFQ1	IOMQ (1)	IF14C / IF18C

Ice Maker Warranty

Every Ice-O-Matic ice maker is backed by a warranty that provides both parts and labor coverage.

- Three years **Parts and Labor**.
- Five years **Parts** coverage on the compressor.

Ice Form



FLAKED ICE

Bin Chart *Kits for Combining Wider Bins with Smaller Models*

ICE STORAGE BINS											
Kits	Model No.	B25	B40	B42	B55	B700	B1000	B110	B1300	B1325	B1600
	Capacity Width	242 lbs (110 kg) 30 in (762 mm)	344 lbs (156 kg) 30 in (762 mm)	351 lbs (160 kg) 22in (559 mm)	510 lbs (232 kg) 30 in (762 mm)	680 lbs (308 kg) 30 in (762 mm)	1000 lbs (454 kg) 30 in (762 mm)	854 lbs (388 kg) 48 in (1219 mm)	1320 lbs (599 kg) 48 in (1219 mm)	1325 lbs (601 kg) 60 in (1524 mm)	1660 lbs (753 kg) 60 in (1524 mm)
MFIO800		KBT19		KBT24	KBT19	not recommended		KBT23	●●	●●	
MFIO800 (2)		N/A						KBT22	●●*	●●*	
MFIO805		KBT19		KBT24	KBT19	not recommended		KBT23	●●	●●	
MFIO805 (2)		N/A						KBT22	●●*	●●*	

See Ice-O-Matic Price List for Adapter Kits to combine ice makers with most available ice/beverage dispensers.

●● Kit not required. Hold down securement recommended.

*Must be specified as a two machine, side-by-side application when ordering or additional charges will apply.



Air Cooled

Please note: air-cooled units require 6" (152 mm) clearance for air intake and exhaust.

- A. Ice maker potable water in, 3/8" FPT.
- B. Drain, 3/4" FPT.
- C. Hole for electrical connection.
- D. Condenser inlet (water cooled only) 3/8" FPT.
- E. Condenser drain (water cooled only) 1/2" FPT.
- F. Liquid line, 3/8" male coupling for precharged line set (remote only).
- G. Discharge line, 1/2" male coupling for precharged line set (remote only).
- H. Remote condenser junction box (remote only).

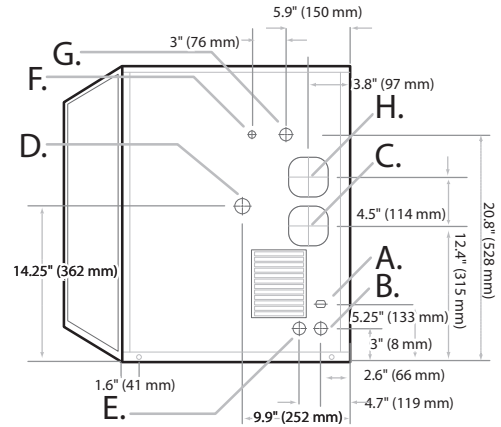
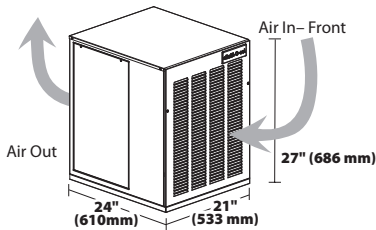
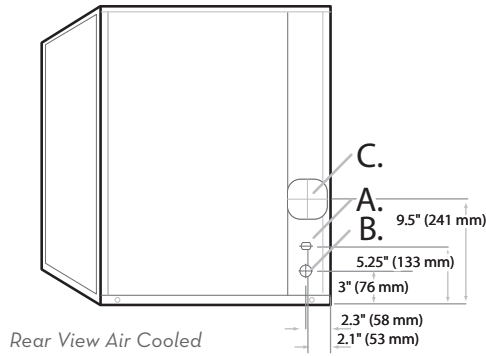

Operating Requirements

	MINIMUM	MAXIMUM	
		60 Hz	50Hz
Ambient Temp. Range Air	50°F (10°C)	100°F (38°C)	110°F (43°C)
Water Temp.	40°F (4.4°C)		90°F (32°C)
Water Pressure	20 PSIG (1.4 BAR)	120 PSIG (8.3 BAR)	

Dimensions

ALL MODELS	
W x D x H (in.)	21 x 24 x 27
W x D x H (mm)	533 x 610 x 686

Specifications

Model Number	Cond. Unit	Ice Production per 24 hrs		Water Usage gallons per 100 lbs of Ice		kWh Used per 100 lbs of ice @ 90°F air/70°F water	Voltage Characteristics	Min. Circuit Ampacity	Fuse Size	Approx. BTUs** per hour
		70°F air/50°F water lbs (kg)	90°F air/70°F water lbs (kg)	Potable	Condenser					
MFIO800A	Air	900 (408)	665 (302)	12.0 (45.4)	-	3.80	115/60/1	21.0	30	7,400
MFIO800W	Water	940 (426)	740 (336)		100	3.00		19.5		4,400
MFIO800R	Remote*	925 (420)	650 (295)		-	4.75		23.5		5,600
MFIO805A	Air	735 (333)	540 (245)		-	3.80	220-240/50/1	10.1	15	7,400
MFIO805W	Water	737 (334)	604 (274)		125	3.25		9.5		4,400

*Requires RGA-1001-HM Remote Condenser with optional grill guard kit. When installing a modular MFI on a drink dispenser, the KGEMDISP MUST be used.

**BTUH is calculated to 0°F Evaporator, 100°F Condensing, and 33 PSIG.

NOTES:

Number of Wires: 3 (including ground)
 Approx. Shipping Weight lbs (kg): MFIO800A 205 (93) • MFIO800W 200 (91 kg) • MFIO800R 220 (100 kg) • MFIO805A 205 (93 kg) • MFIO805W 200 (91 kg)
 Refrigerant Type: R404A